

VIVIENDA 5

ESPACIOS INTERIORES	SUP. UTIL.M2	SUP. CONS.M2
VESTÍBULO	7.40 m2	
ESCALERA	5.75 m2	
ASEO	2.25 m2	
C. INSTALACIONES	1.60 m2	
COCINA	12.90 m2	
SALÓN-COMEDOR	44.60 m2	
TOTAL PLANTA BAJA	74.50 m2	86.57 m2
DISTRIBUIDOR	3.70 m2	
ESCALERA	5.75 m2	
DORMITORIO 1	14.25 m2	
VESTIDOR	9.30 m2	
BAÑO 1	6.30 m2	
DORMITORIO 2	12.40 m2	
BAÑO 2	4.55 m2	
DORMITORIO 3	14.75 m2	
BAÑO 3	5.80 m2	
TOTAL PLANTA PRIMERA	76.80 m2	92.42 m2
ESCALERA	7.30 m2	
BAÑO	3.70 m2	
SALA	18.45 m2	
TOTAL PLANTA DE CUBIERTA	29.45 m2	37.63 m2
ESPACIOS EXTERIORES	SUP. UTIL.M2	SUP. CONS.M2
ACCESO	11.70 m2	
JARDINES DELANTEROS	24.20 m2	
ZONA APARCAMIENTO	28.70 m2	
TERRAZA	61.80 m2	
JARDINES TRASEROS Y PISCINA	27.80 m2	
SOLARIUM	42.25 m2	
TOTAL TERRAZAS Y JARDINES	196.45 M2	
TOTAL SUPERFICIE ÚTIL	180.75 M2	
TOTAL SUPERFICIE CONSTRUIDA		216.62 M2

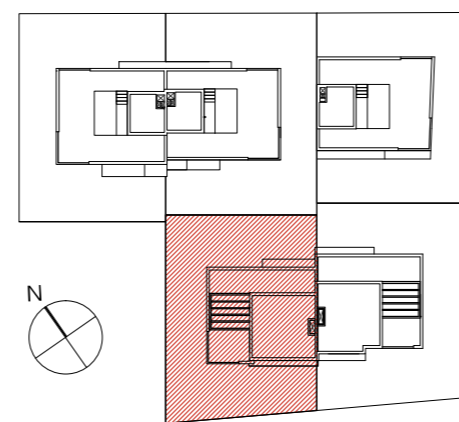
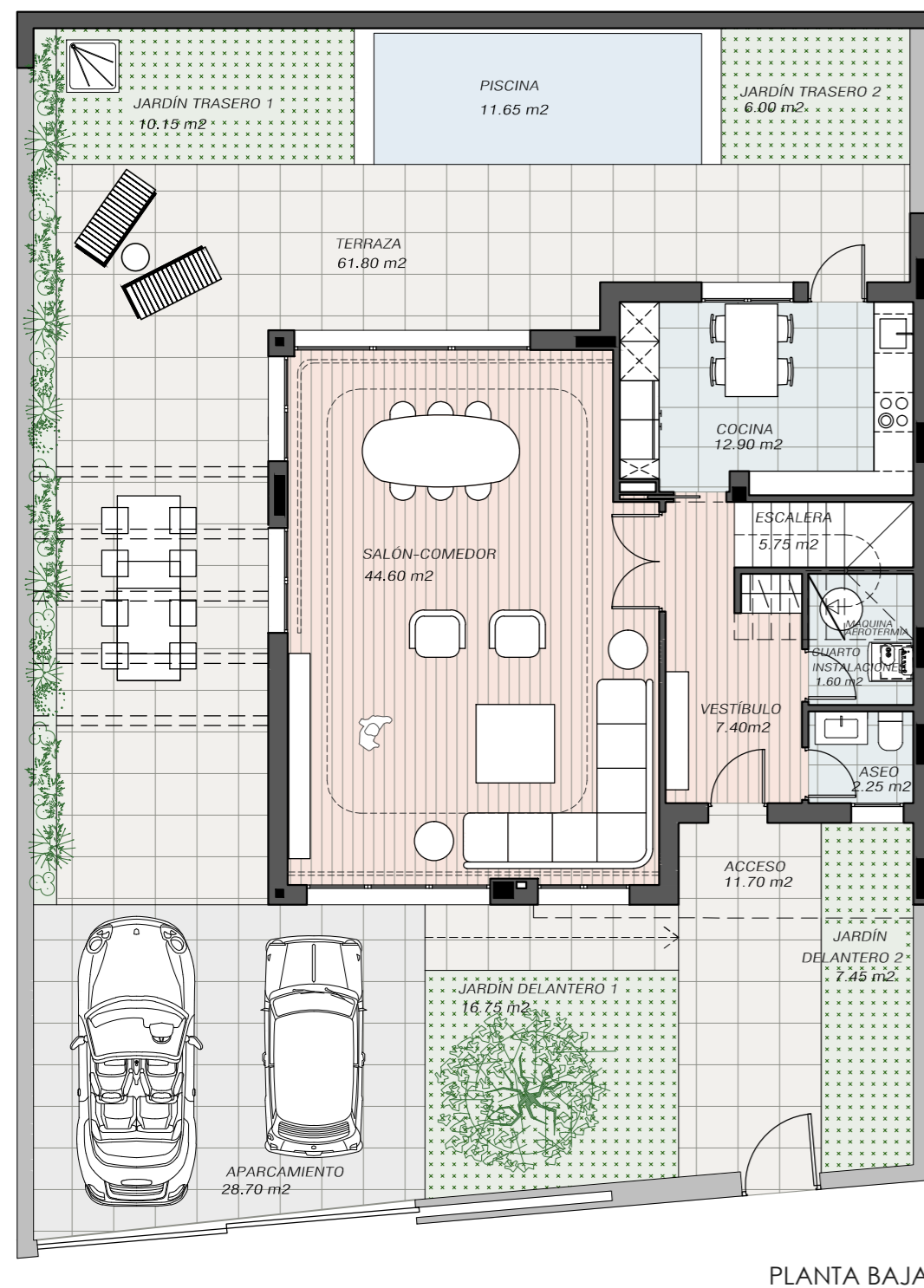
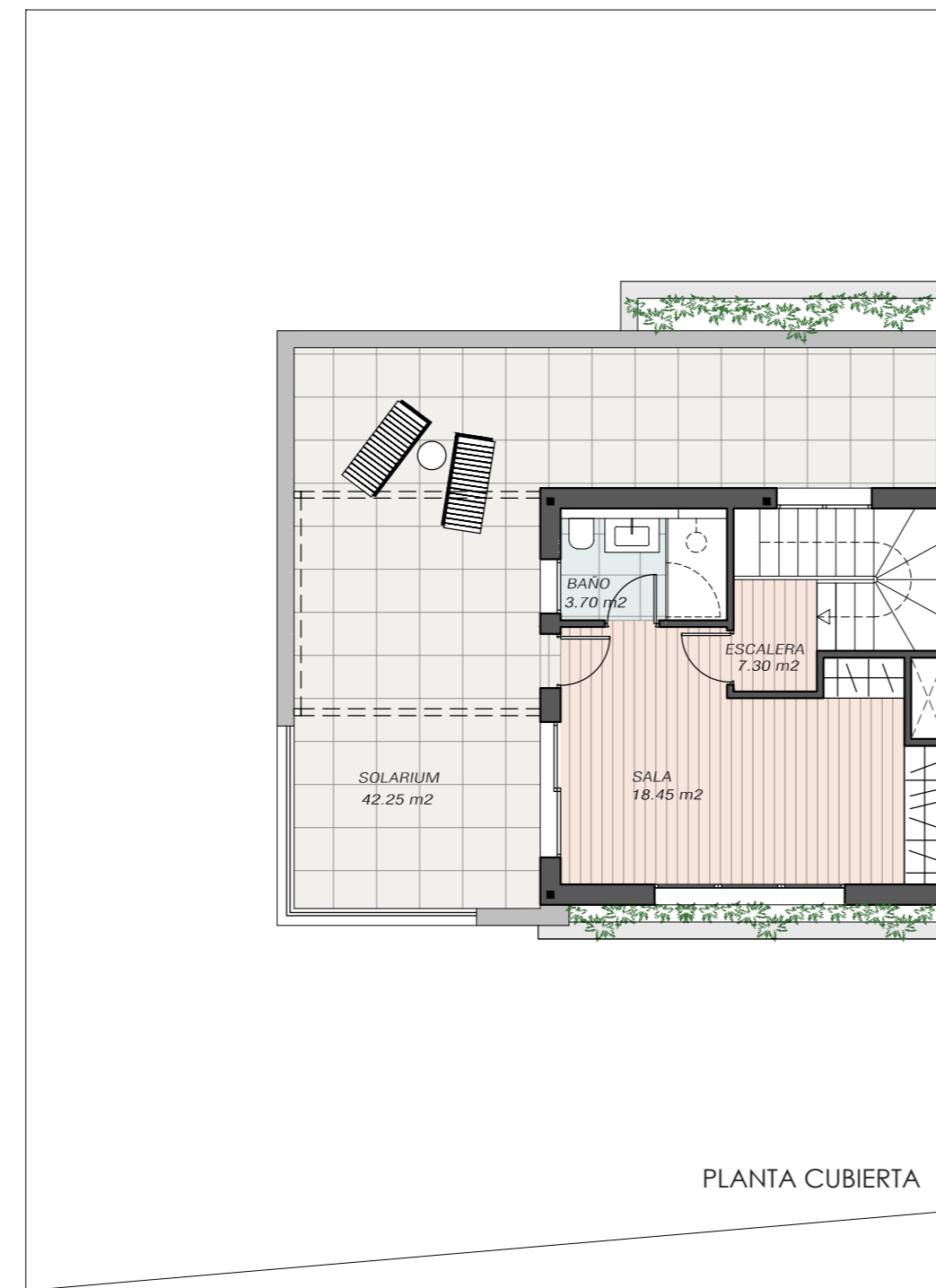
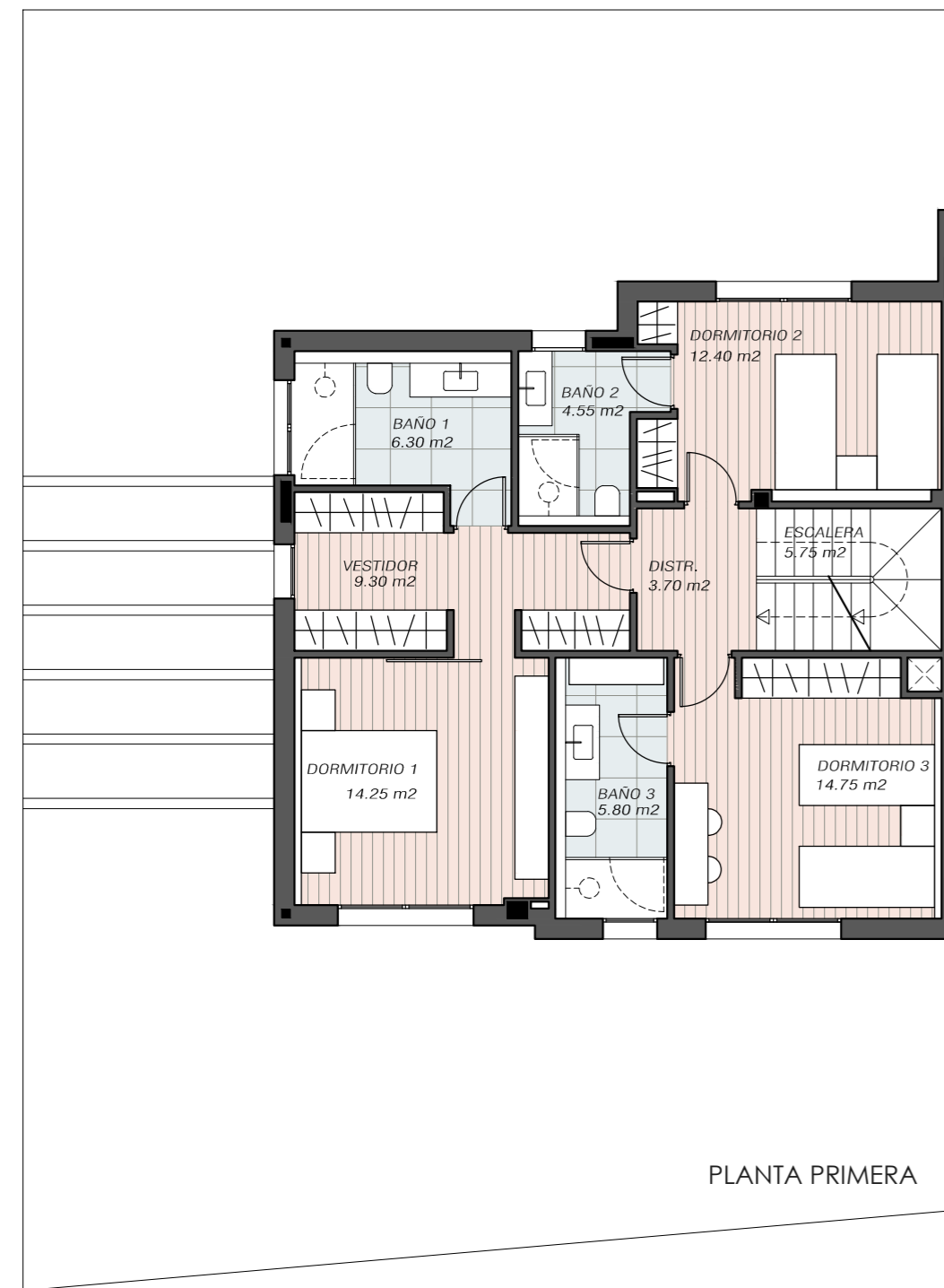

PROYECTO 5 VIVIENDAS UNIFAMILIARES Y PISCINAS MANZANA A. UE DEL AUC 08.02 "ANGELITA CAMARERO". MADRID	JUNIO - 2024	
	VIVIENDA 05. DISTRIBUCIONES Y SUPERFICIES.	
Félix María González Vello Blanca González García Jaime González García Arquitectos C/ Andrés Mellado 31. 28015 MADRID T. 91.057.61.56	FRONTAL XXI, S.L. Promotor	0.4 04/24

MANZANA A / PARCELA R5 16B

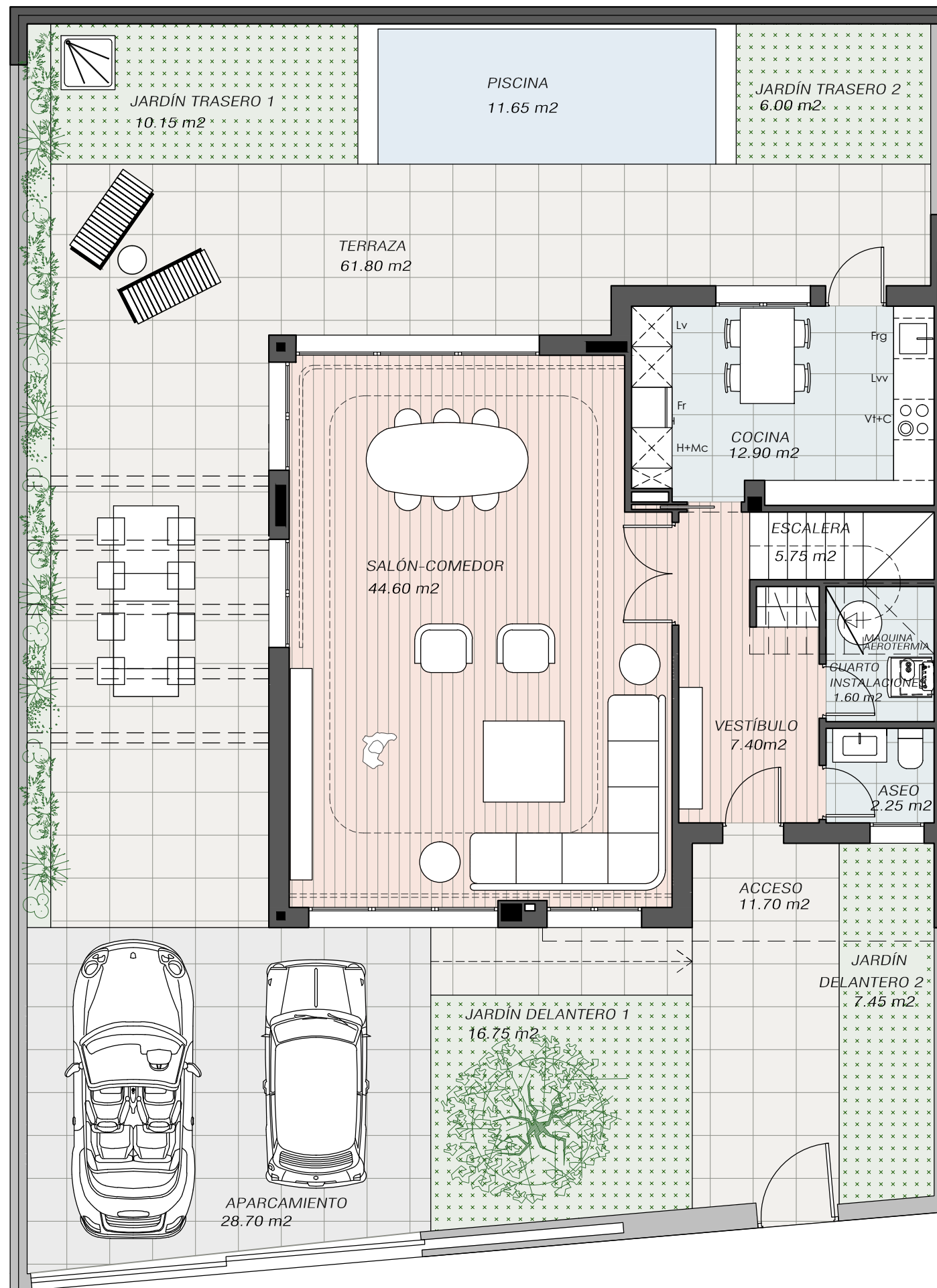
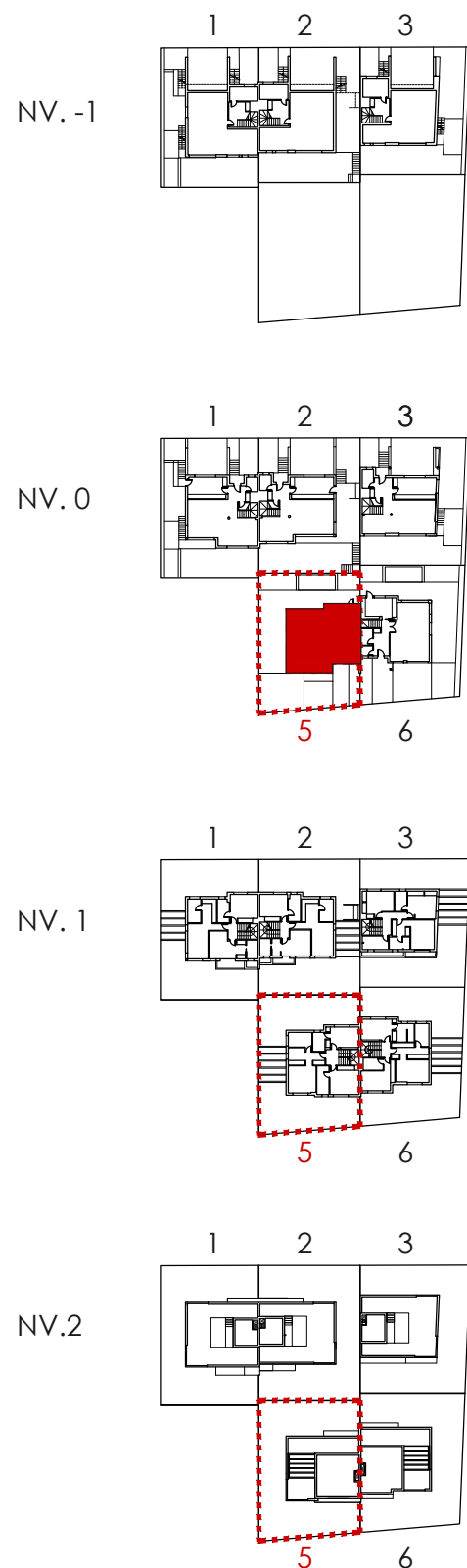

VIVIENDA 5 PLANTA BAJA

SUPERFICIES ÚTILES	
VESTÍBULO	7.40 m ²
ESCALERA	5.75 m ²
ASEO	2.25 m ²
C.INSTALACIONES	1.60 m ²
COCINA	12.90 m ²
SALÓN-COMEDOR	44.60 m ²
SUP. ÚTIL PLANTA	
	74.50 M ²
SUP. ÚTIL TOTAL	
	180.75 M ²

SUPERFICIES CONTRUIDAS	
SUP. CONSTRUIDA PLANTA	86.57 M ²
SUP. CONSTRUIDA TOTAL	216.62 M ²

ESPACIOS EXTERIORES	
ACCESO	11.70 m ²
JARDINES DELANTEROS	24.20 m ²
APARCAMIENTO	28.70 m ²
TERRAZA	61.80 m ²
JARDINES TRASEROS Y PISCINA	27.80 m ²

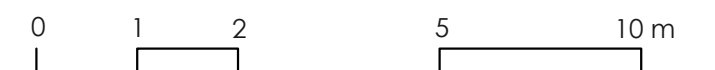
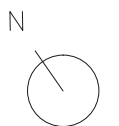

MANZANA A / PARCELA R5 16B

VIVIENDA 5 PLANTA PRIMERA

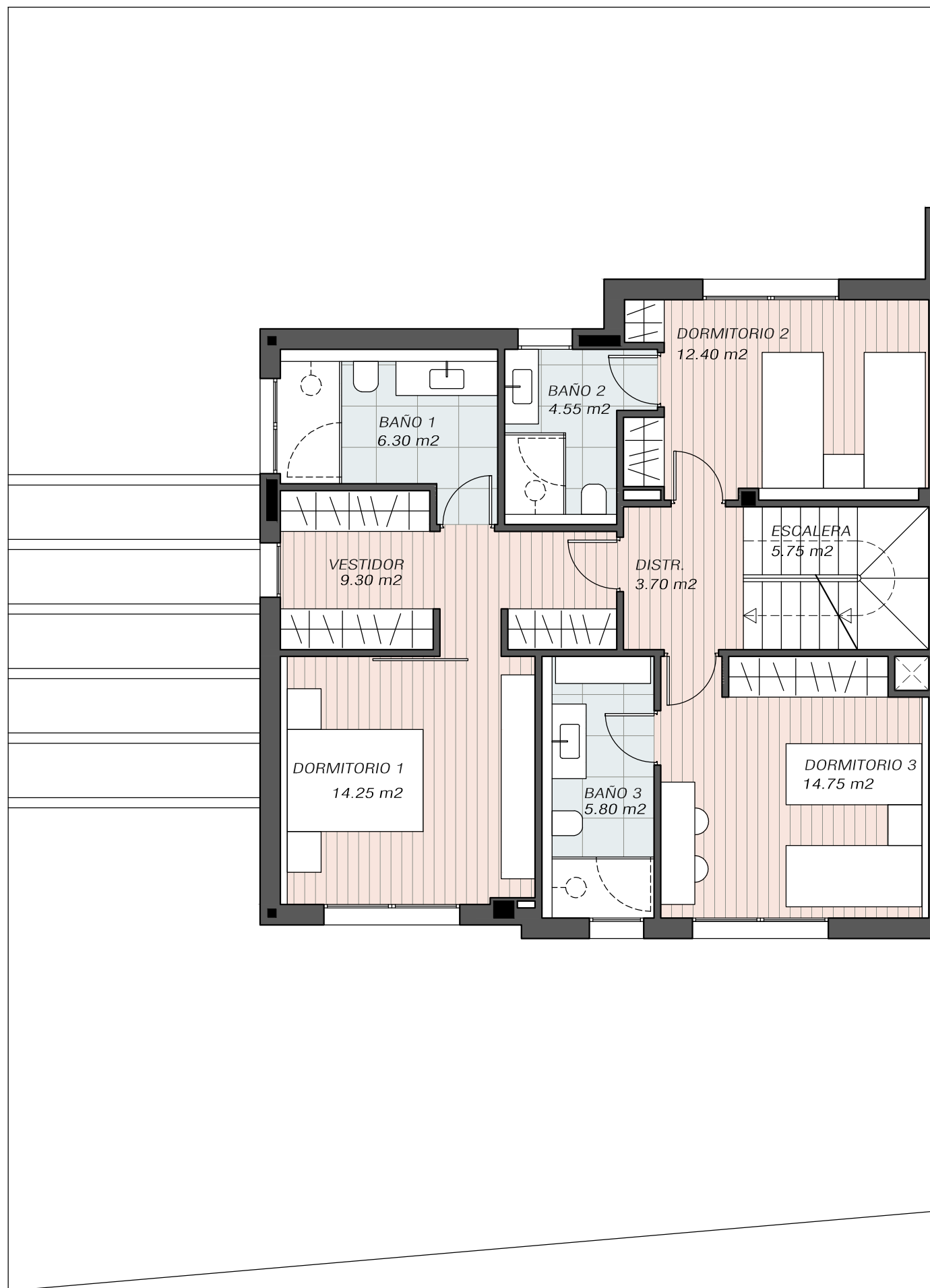
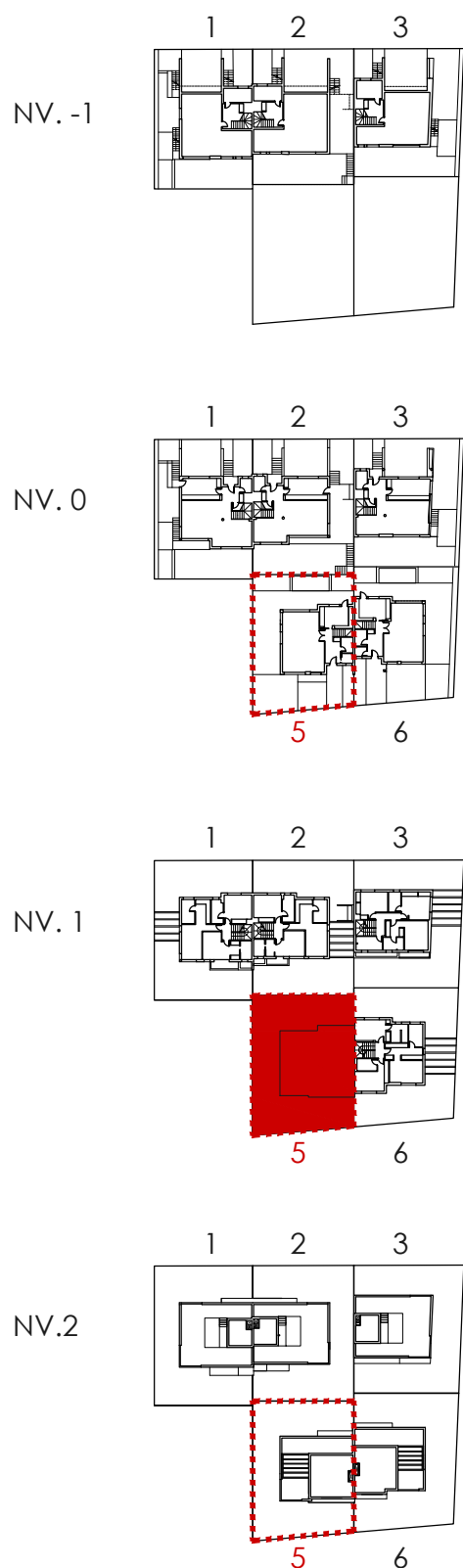

SUPERFICIES ÚTILES	
DISTRIBUIDOR	3.70 m2
ESCALERA	5.75 m2
DORMITORIO 1	14.25 m2
VESTIDOR	9.30 m2
BAÑO 1	6.30 m2
DORMITORIO 2	12.40 m2
BAÑO 2	4.55 m2
DORMITORIO 3	14.75 m2
BAÑO 3	5.80 m2
SUP. ÚTIL PLANTA	76.80 M2
SUP. ÚTIL TOTAL	180.75 M2

SUPERFICIES CONTRUIDAS	
SUP. CONSTRUIDA PLANTA	92.42 M2
SUP. CONSTRUIDA TOTAL	216.62 M2

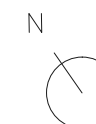

MANZANA A / PARCELA R5 16B

VIVIENDA 5 PLANTA CUBIERTA

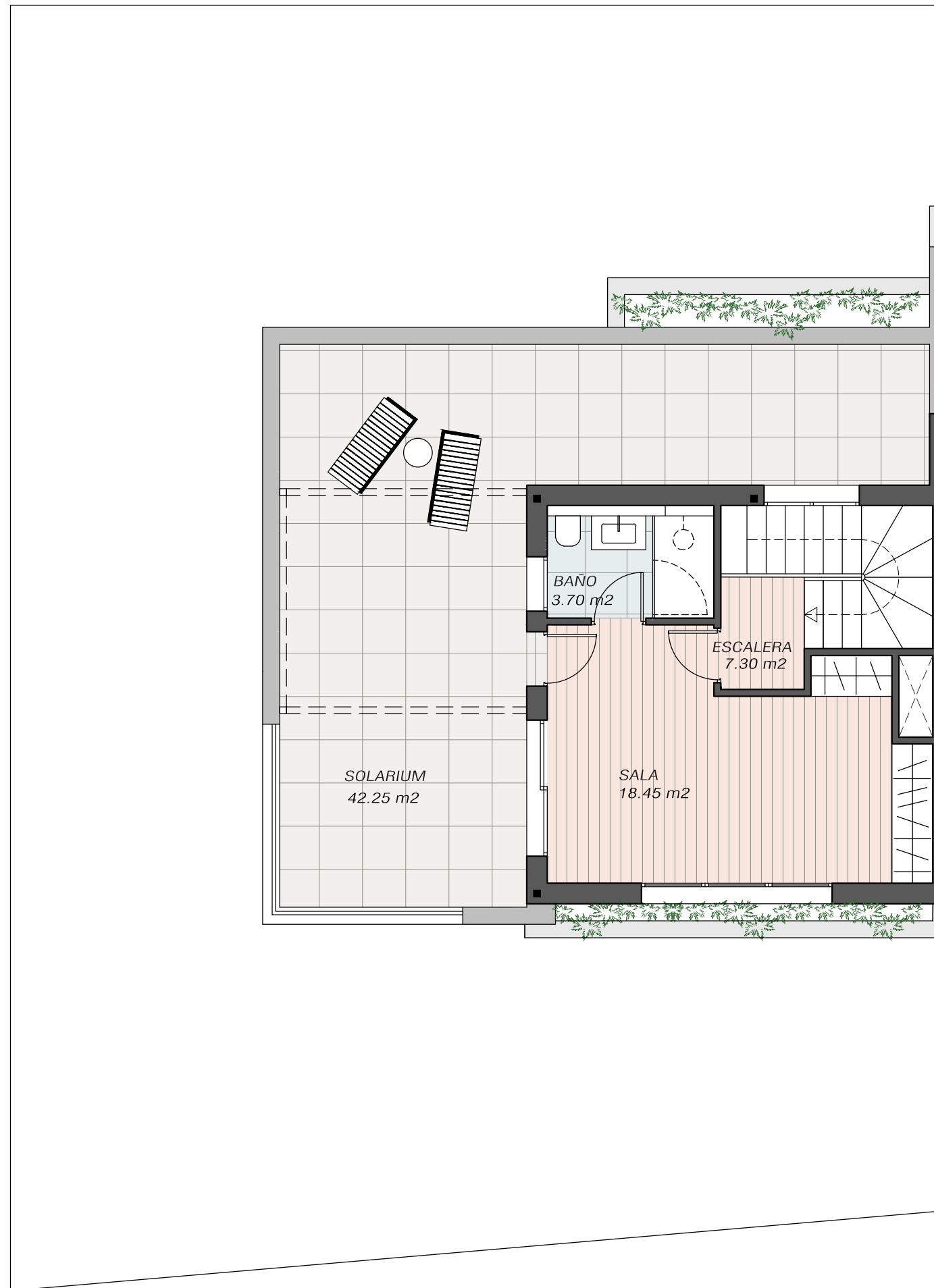
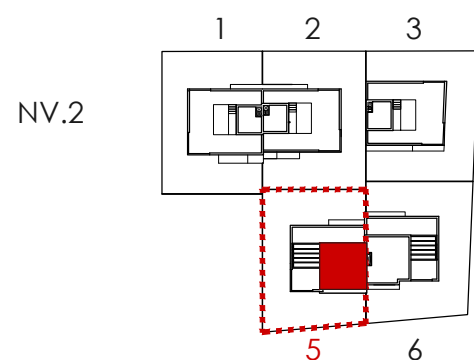
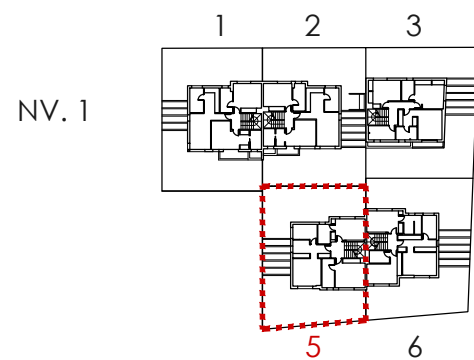
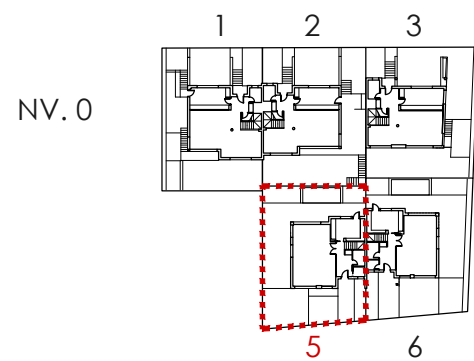
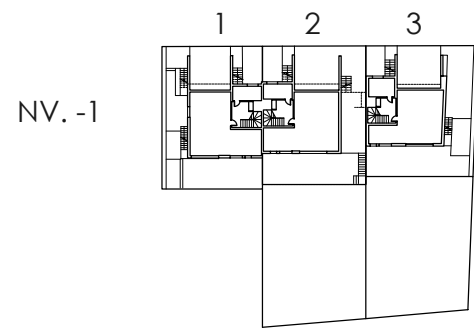

SUPERFICIES ÚTILES	
ESCALERA	7.30 m ²
BAÑO	3.70 m ²
SALA	18.45 m ²
<hr/>	
SUP. ÚTIL PLANTA	29.45 M ²
SUP. ÚTIL TOTAL	180.75 M ²
SUPERFICIES CONTRUIDAS	
SUP. CONSTRUIDA PLANTA	37.63 M ²
SUP. CONSTRUIDA TOTAL	216.62 M ²
ESPACIOS EXTERIORES	
SOLARIUM	42.25 m ²

